

# Operating Manual

for

**NOVOpress**

**Bending Table  
BGD5eco**

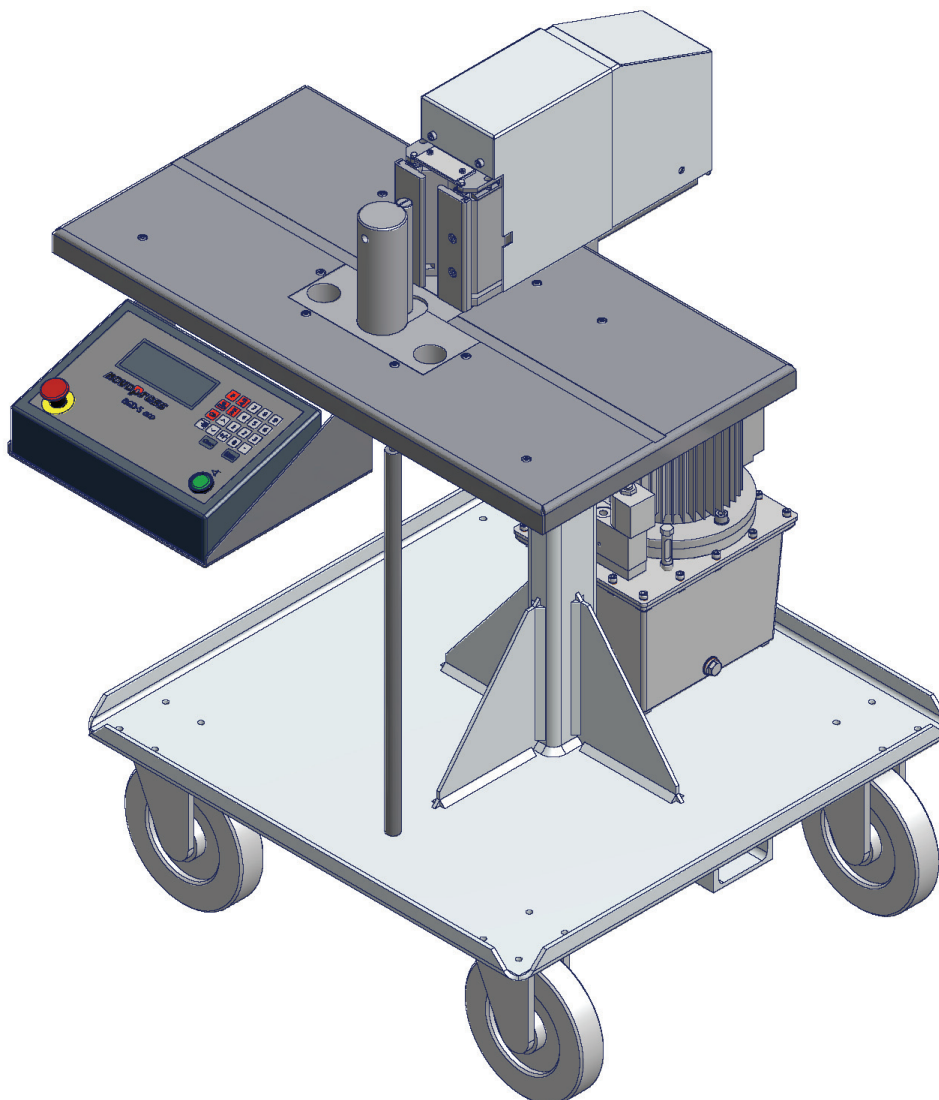

# Contents

Safety regulations	
1	Scope of supply..... 1
2	Introductory notes ..... 1
3	Basic safety information ..... 1
4	Installing the control unit ..... 2
5	Intended use ..... 4
6	Technical data..... 5
7	Special safety instructions ..... 6
8	Important general information on bending ..... 6
	8.1 Thrust pads (3) ..... 6
	8.2 Bending radius and bending mandrel..... 7
	8.3 Control bar ..... 7
	8.4 Measuring scale..... 7
	8.5 Smallest bending radius ..... 7
	8.6 Smallest shank length..... 7
	8.7 Bending angles ..... 8
	8.8 Bending button..... 8
	8.9 Stand-by..... 8
	8.10Support arm ..... 8
9	Keyboard description ..... 9
10	Commissioning..... 10
11	Bending ..... 12
	11.1Bending and compensation (function F1)..... 12
	11.2Stroke limit (function F6)..... 13
	11.3Bending using the Repeat key  ..... 15
	11.4Bending bars less than 5 mm thick (F4 bending without compensation) ..... 16
12	Step bending tools ..... 17
	12.1Range of application ..... 17
	12.2Installing the step bending tool ..... 17
	12.3Inching mode ..... 18
	12.4Stroke..... 19
	12.5Step bending tool (small), order no.: 31671 ..... 20
	12.6Step bending tool (large), order no.: 31188..... 21
13	Upright bending tool, order no. 31221 ..... 22
	13.1Range of application ..... 22
	13.2Installing the upright bending tool ..... 22
	13.3Procedure ..... 23
14	Additional bending tool for small lug lengths, order no.: 31850..... 24
	14.1Range of application ..... 24
	14.2Installing the additional bending tool ..... 24
	14.3Bending..... 24
15	Hydraulic unit HA3 BGD 400V ..... 25
16	Table of functions/ brief instructions ..... 26

17	Setting options for the user in the menu 	27
17.1	User Level.....	27
17.2	Setter Level.....	30
18	Adjusting the bending factor .....	33
19	Error messages.....	36
20	Required space, installation and assembly .....	37
20.1	Required space.....	37
20.2	Installation.....	38
20.3	Installing the support arm .....	38
20.4	Commissioning .....	38
21	Maintenance of the bending table.....	39
21.1	Displaying the number of previous bends .....	39
22	Maintenance of the hydraulic unit HA3 BGD 400V.....	41
23	Fuses and pin assignment.....	43

## GENERAL SAFETY REGULATIONS

### **Read all safety regulations and instructions!**

1. Keep the place of work clean.  
Disorderly work-places and work-benches invite accidents.  
Ensure that lighting is good.
2. Keep children away.  
Do not allow unauthorised persons to touch the device or the cable.  
Keep unauthorised persons away from your place of work.
3. Wear suitable working clothing.  
Do not wear any wide clothes nor jewellery - they may get caught up in moving parts.  
When working in the open it is recommended that you wear rubber gloves and non-slip footwear. Wear a hair- net if you have long hair.
4. Always be alert.  
Only use a device after having been instructed in its operation.  
Concentrate on your work. Proceed sensibly.  
Do not use the device when you are distracted.
5. Do not lean too far forward. Avoid abnormal stance.  
Make sure that you have a secure standing position, and maintain balance at all times.
6. Leave safety devices where they belong.
7. Hand tools may not be installed as fixtures.
8. Repair and maintenance.  
Have repairs and maintenance work carried out in an authorised NOVOPRESS specialist workshop.  
Only use original and identical NOVOPRESS spare parts.  
We reject all responsibility and liability for work carried out by third- party persone
9. Our machines are not UL certificated. They may not be exported and used for USA and Canada.

## SAFETY INSTRUCTIONS FOR HYDRAULIC EQUIPMENT

1. Please read the operating instructions.  
Acquaint yourself with the hydraulic equipment.
2. Provide the equipment with the necessary care.  
Always keep the equipment in operational condition.  
Cleanness is an essential requirement for good and safe working.
3. Switch off the electric power supply to the hydraulic equipment,
  - when the equipment is not in use
  - when maintenance work is to be carried out.
4. Avoid unintentional switching - on.  
Keep hands and feet away from the switch when the equipment is not being used.
5. Do not use the equipment in a manner in contravention of the instructions.  
Never carry the equipment by the pipe or pull on the pipe.  
Protect the piping from heat, oil, sharp edges and high levels of weight strain.
6. Use only piping, fittings and accessories which have been designed for the operating pressure of the hydraulic unit.  
**BURSTING PRESSURE OR TEST PRESSURE IS NOT OPERATING PRESSURE!**  
Avoid squashing or bending of the piping.  
Piping must not be painted over.
7. Replace the hydraulic piping
  - when cracks, squashed or bent points are to be seen
  - when blistering is established
  - when hydraulic fluid escapes
  - when pipe fittings are damaged
  - when discolouration is established on the outer layer, e.g. due to the influence of solvents.
8. The hydraulic fluid used in the system is kerosene-based.  
This requires particular care and attention.
  - Avoid continuous contact with the skin
  - ensure that the hydraulic fluid does not get into the eyes or mouth.Hydraulic pipes have to be replaced after 5 years of usage, despite of the circumstance that no damages should be remarkable.
9. The equipment must not be operated, if it has leaks and there is a danger of hydraulic fluid coming into contact with persons, open fire, heating equipment, electric cabling, ground water, foods and other substances which are intended for human consumption.
10. Hydraulic units with petrol engines
  - must not be operated in closed rooms, due to the **DANGER OF INTOXICATION!**
  - do not pour in petrol while the motor is running or in the vicinity of open fire. **DANGER OF EXPLOSION!**

## SAFETY TIPS FOR ELECTRIC TOOLS

**ATTENTION: In order to avoid electric shock, danger of injury and burning the following basic safety measures are always to be taken when using electric tools. Read and observe the notes before using the device. Keep the safety tips in a safe place.**

1. Take influences of the surroundings into account.  
Do not expose electric devices to rain.  
Do not use electric devices in damp or wet surroundings.  
Do not use electric devices in the vicinity of flammable liquids or gases.
2. Protect yourself from electric shock.  
Do not fix additional rating plates or symbols with rivets or screws.  
Use adhesive signs. When working with electric devices avoid body contact with earthed objects such as pipes, heating appliances, refrigerators etc.
3. Use the correct tools.  
Only use the tools and accessories outlined in the operating instructions.  
Do not use the electric device to do work for which it is not intended.
4. Secure the work piece.  
Use gripping devices or vice grips to hold the work piece steady.  
It is more securely held than by hand and you can operate the device with two hands.
5. Do not overload your electric device.  
You can work better and more securely in the indicated power range.
6. Do not use the cable for purposes for which it is not intended.  
Do not carry the electric device by the cable.  
Do not use the cable in order to pull the plug out of the socket. Protect the cable from heat, oil, acids and sharp edges.  
For working in wet rooms or in the open only use the authorised extension cables with the corresponding marking.
7. Avoid unintentional starting.  
Ensure that the electric device is switched off before connecting the mains plug.  
Do not carry the electric device in such a way as that your finger is on the switch.  
Do not use the electric device if the ON/OFF switch does not work perfectly.
8. Disconnect the mains plug:
  - if the device is not in use
  - before maintenance of the electric device
  - when changing tools
9. Carefully maintain the electric device. The best and most secure work is guaranteed if you:
  - keep the electric device clean
  - observe the instructions for greasing, changing the tools and ancillary equipment
  - regularly check the connection cable and the extension cable
  - have damaged cables repaired by a specialist
  - keep hand grips dry, clean and free from oil and fat
  - have the electric device examined and cleaned by a specialist after 900 operating hours.

10. Keep electric devices in a safe place.  
Store electric tools and accessories out of the reach of children, in dry, high-lying places or in locked rooms.
  
11. Electric devices are often used by more than one person. Therefore before beginning to work you should check:
  - the socket to ensure it is securely fixed and is not damaged in such a way as can be seen from the outside
  - the connection cable for outward damage to the insulation and for sharp kinks
  - that the cable is securely fixed to the device and whether the insulating plastic tube is damaged
  - that the switch is secure and shows no outward signs of damage
  - whether protective appliances or damaged parts function properly
  - whether movable parts jam or are damaged
  - do not use the device in the event of finding defects
  - only allow the device to be repaired by a specialist or in an authorised NOVOPRESS specialist work-shop
  - only use original and identical NOVOPRESS spare parts.

## 1 Scope of supply

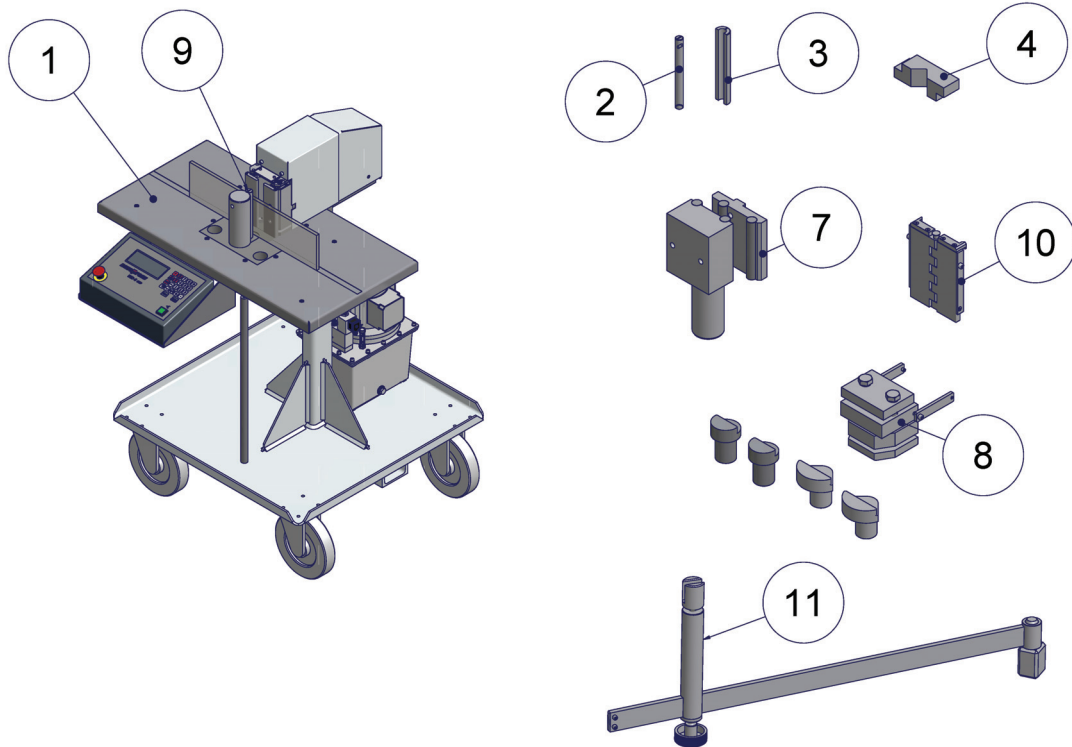

- BGD 5eco (1) with hydraulic unit attached
- Bending radii 7.5mm (2), 10mm (9) and 15mm (3)
- Control bar (4)
- Attachments:
 

Step bending tools (7):	Small	Order no.: 31671
	Large	Order no. 31188
Upright bending tool (8)		Order no.: 31221
Bending hinge (10)		Order no.: 31850
Support arm (11)		Order no.: 43255

## 2 Introductory notes

- In the following text, the keys which need to be pressed are indicated by bold type, e.g. **F**, **Enter** etc.
- Text printed in italics, e.g.: *The display will indicate*, contains instructions or sequence descriptions related to the previously described operation.

## 3 Basic safety information

The following pictograms will be used to highlight sections of text. Please follow these instructions and act with special caution in these cases. All working safety instructions must also be passed on to other users/ specialist technicians.

### **Warning!**



***For your own safety and to protect your bending table, please follow the instructions in the text passages marked with this symbol.***



**Note!**

*This information is directly linked to the description of a function or an operating sequence.*

**Please read this Operating Manual carefully.**

**The attached safety instructions must be observed.**

**Symbols on the device****Warning: Hand risks being crushed**

Keep hands away from the working area of the bending table.

## 4 Installing the control unit

**Warning!**

*The mains plug must only be plugged in when all the connectors have been attached to the control unit.*

**Non-compliance will lead to damage to the BGD.**

1. In the table reinforcement there are 2 nuts with 2 screws in them. Undo the screws and remove them together with the washers.
2. If necessary, align the nuts so that the control unit can be screwed on.

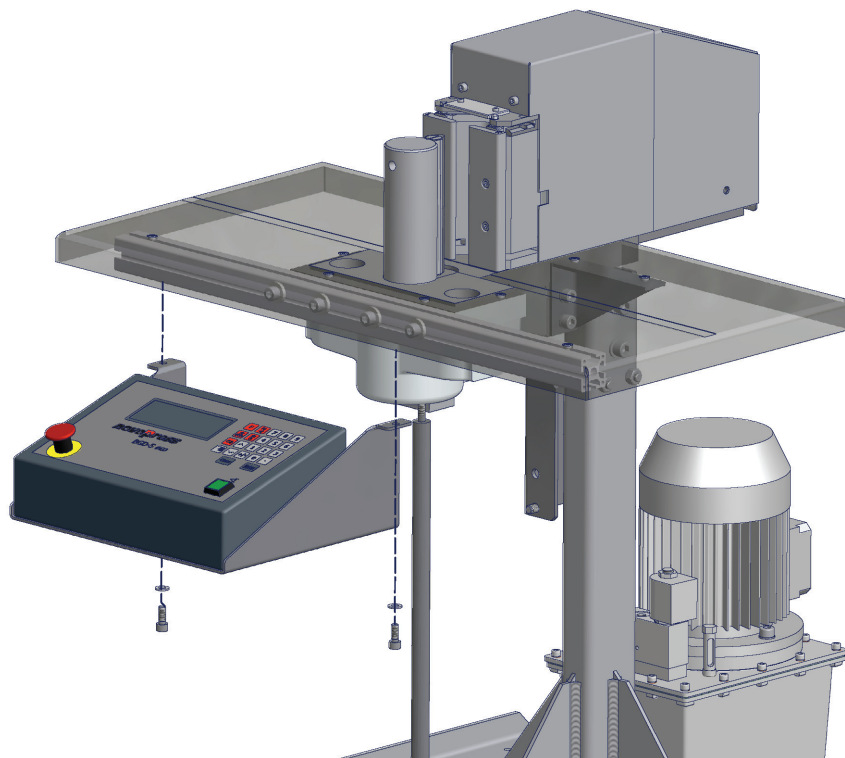

3. Screw the control unit onto the bending table loosely.

4. All the connectors have a different socket insert. Insert the connectors and screw them on tightly. If necessary, adjust the control unit position.
5. Tighten the 2 screws.
6. Plug in the mains plug.
7. Pull out the emergency off button.
8. Set the zero point (see Commissioning section).
9. If the motor is running but the BGD's tool holder does not move forwards, the motor's direction of rotation can be changed as follows.
10. Disconnect from mains.



**Note!**

***The mains plug must not be dismantled.***

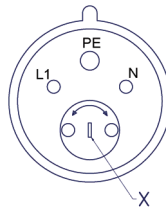

11. There are 2 rotateable plug contacts on the mains plug.  
Insert a screwdriver into groove X and rotate the plug contacts by 180°.
12. Plug the mains plug back in.

## 5 Intended use

It is possible to bend the following with this bending table:

- Copper and aluminium bus bars up to a max. of 160 x 13mm.
- Flat steel bars up to 100 x 10 mm with a strength of up to a max. of 370 N/ mm<sup>2</sup>.

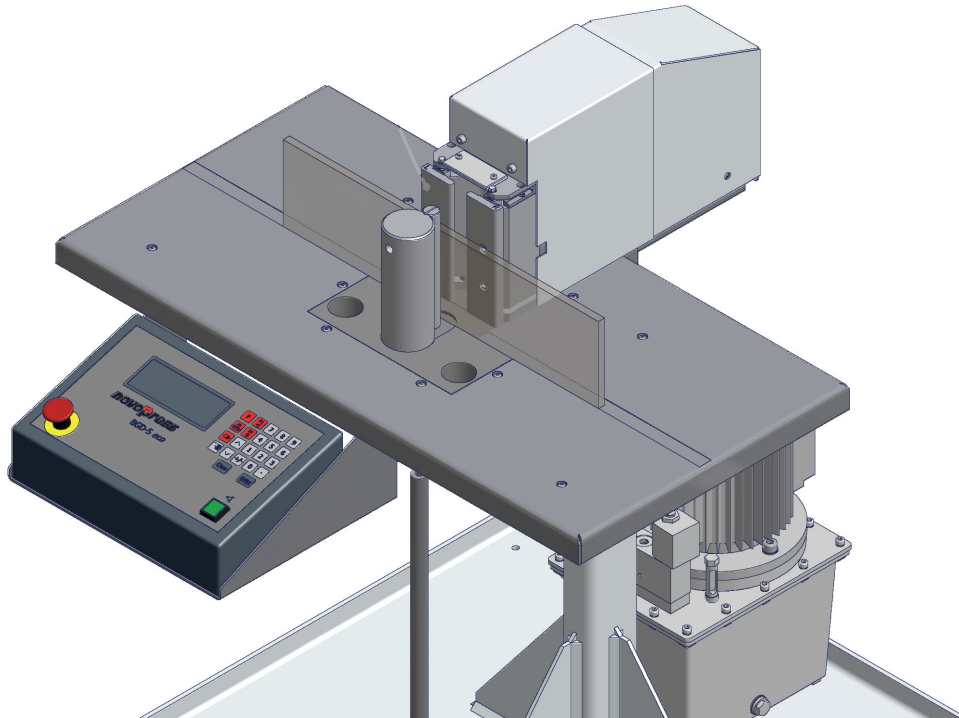

If no special tool is used, the bars may only be inserted and bent in the way shown.

### **Warning!**



- Upright bending of bars is only permitted when using the appropriate special tool.
- Once bent, a bar may not be bent back again.

**Non-compliance will lead to damage to the BGD.**

Any other or additional use is regarded as non-intended.

Novopress is not liable for any resulting consequences or damage. Neither is it liable for tools of other manufacturers nor for any damage caused by such tools.

Intended use also includes observance of the Operating Manual, adherence to the inspection and maintenance conditions as well as compliance with all the relevant safety regulations.

## 6 Technical data

### BGD5eco

Height:	approx. 1330	mm
Width:	approx. 830	mm
Depth:	approx. 950	mm
Table height:	approx. 1080	mm
Weight:	approx. 180	kg
Max. compression force:	150	kN
Max. stroke:	95	mm
Max. feed rate:	<10	mm/s
Voltage:	see rating plate (neutral conductor used)	
Type of protection:	IP44	
Ambient temperature:	+5°C to +40°C	
Relative humidity:	Max. 95% non-condensing	
Installation location of BGD5eco:	Max. 2000 m above sea level	

Only store and operate the BGD5eco in closed rooms.

### Hydraulic unit HA3-BGD 400V

#### Electrics:

Motor:	
Supply voltage:	see rating plate
Frequency:	see rating plate

Frequency	50 Hz	60 Hz
RPM	2800 min <sup>-1</sup>	3300 min <sup>-1</sup>
Power consumption	750 W	750 W

#### Hydraulics:

Pump:

Frequency	50 Hz	60 Hz
Delivery rate	3.5 l/min	3.3 l/min

Operating pressure: max. 200 bar

Dimensions:

Height:	approx. 460	mm
Width:	approx. 250	mm
Depth:	approx. 290	mm

Hydraulic oil: Oil used at the factory for this unit:  
ISO VG 32 DIN 51519  
(suitable for ambient temp. range of +5 to +40° C)

Oil suitable for use:  
Oil of viscosity class:  
ISO VG DIN 51519 from 10 to 46  
(Viscosity in CSt 7.4 - 30 at 50° C.)

## 7 Special safety instructions

### **Warning!**



- Bus bars over 13 mm in thickness may **not** be bent.
- Upright bending of bars is only permitted when using the appropriate special tool.
- Once bent, a bar may not be bent back again.

**Non-compliance will lead to damage to the BGD.**

## 8 Important general information on bending

### 8.1 Thrust pads (3)

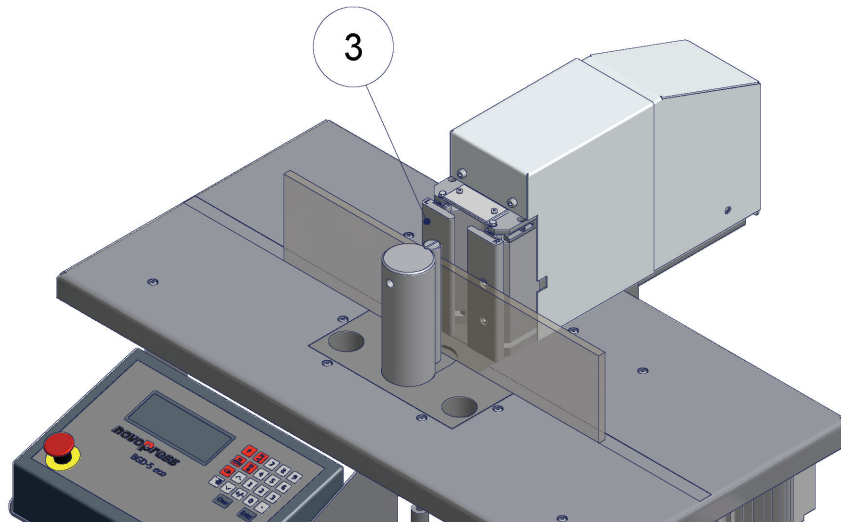

### **Warning!**



- **Bars with a width > 120 mm or with a thickness > 10 mm**  
These bars must be bent without thrust pads (3).
- **Bars up to 120 mm in width or up to 10 mm thick (inclusive)**  
These bars must be bent with attached thrust pads (3).

**Non-compliance will lead to damage to the BGD.**

Example:	Bar 40 x 8	with thrust pads (3)
	Bar 120 x 12	with thrust pads (3)
	Bar 100 x 13	without thrust pads (3)
	Bar 160 x 10	without thrust pads (3)
	Bar 160 x 13	without thrust pads (3)

### Procedure for attaching and removing the thrust pads (3)

- Switch off the EMERGENCY OFF button (push).
- Unscrew the thrust pads (3).
- Set the zero point (see Point 10 Commissioning).
- Perform bending operation.

When bending is completed, replace the thrust pads (3) for smaller bars.

- Switch off the EMERGENCY OFF button (push).
- Screw on the thrust pads (3).  
Ensure that there is no dirt between the thrust pads.
- Set the zero point (see Point 6 Commissioning).
- Perform bending operation.

## 8.2 Bending radius and bending mandrel

When delivered, the 10 mm bending radius is attached to the bending mandrel.

### **Warning!**



- The zero point may only be set with the 10mm bending radius.
- There is a straight pin located in the bending mandrel for aligning the bending mandrel to the bending tool. This straight pin must engage in the hole of the bending mandrel mounting.

**Non-compliance will lead to damage to the BGD.**

## 8.3 Control bar

### **Warning!**



The control bar must only be used for setting the zero point.

**Non-compliance with this instruction will lead to damage to the control bar and the BGD.**

Only a slight amount of force is needed for calibration when setting the zero point.

The bending process produces a maximum force of 150 kN.

## 8.4 Measuring scale

In order to determine the shank length more easily, a measuring tape is fitted into the workplate.

## 8.5 Smallest bending radius

Cu bars:

Bending radius no smaller than thickness of the bar.

Al bars:

Bending radius no smaller than 1.5 x the thickness of the bar.

## 8.6 Smallest shank length

45 mm

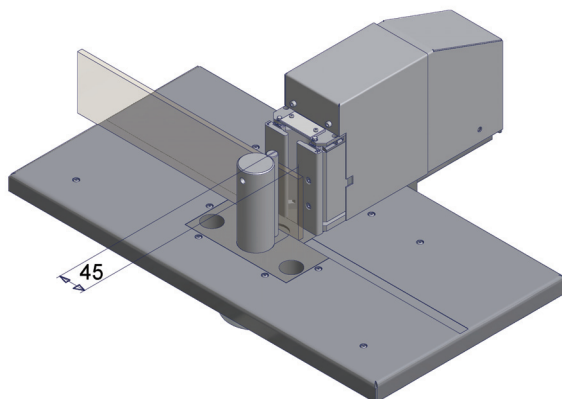

### 8.7 Bending angles

Values between  $0.5^\circ$  and  $93.0^\circ$  may be entered.

### 8.8 Bending button

To perform a bending operation, press the "**Bending** button" on the control unit.

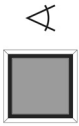

This button is green.  
Hereinafter referred to as "**Bending** button".

### 8.9 Stand-by

The display is empty in stand-by mode.

**To switch the stand-by function on** press

F

0

Enter

The display will then be empty.

**To end the stand-by function** press

F

The zero point has to be reset every time there is an interruption to the power supply, including after the emergency off button has been pressed.  
To avoid having to do this the bending table can be put in stand-by. The display will then be empty.

### 8.10 Support arm

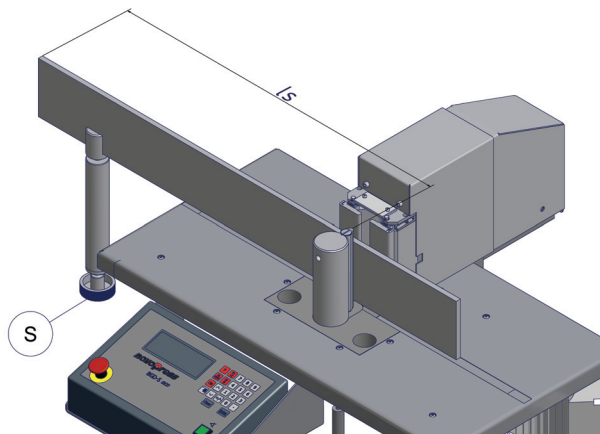

Use the support arm (S) for shank lengths "ls" of 1m to 2m.  
For shank lengths "ls" of more than 2m, support the end of the bar with a stand or something similar.

## 9 Keyboard description

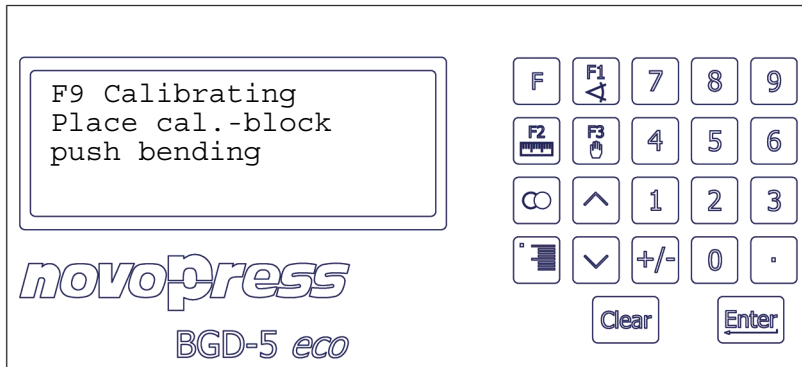

	Bending and compensation
	Stroke
	Inching mode
	Repeat of F1. Bending is performed without compensation.
	Allows the input of code numbers
	Delete an input
	Input confirmation. As long as the input has not been confirmed, the value entered will flash and it can be adjusted.
	Menu access
	Changes the prefix
	Is used to enter a value after the decimal point
	Are used to scroll forwards or backwards



## 10 Commissioning

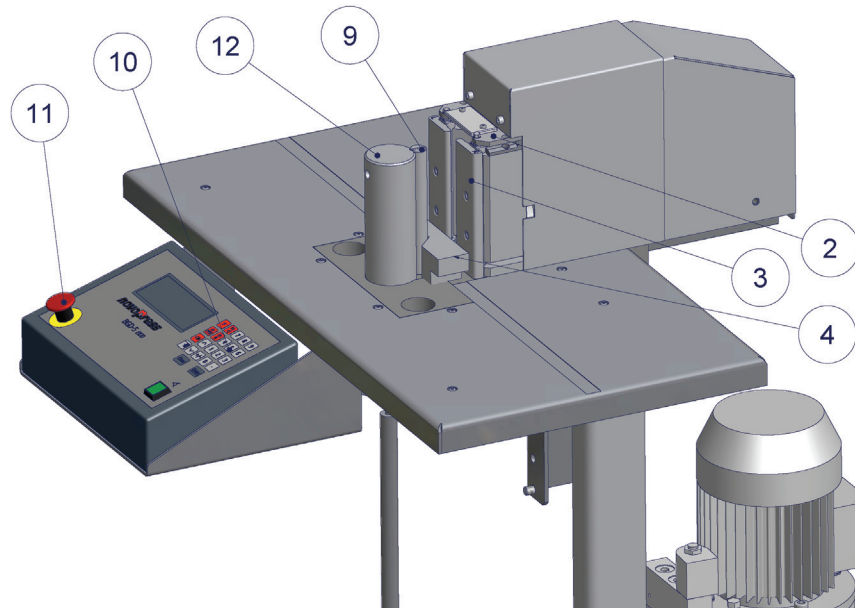

- Connect the BGD to the power supply (for voltage see rating plate).
- Activate the EMERGENCY OFF button (11) (pull).

*The following will appear on the control unit (10) display.*

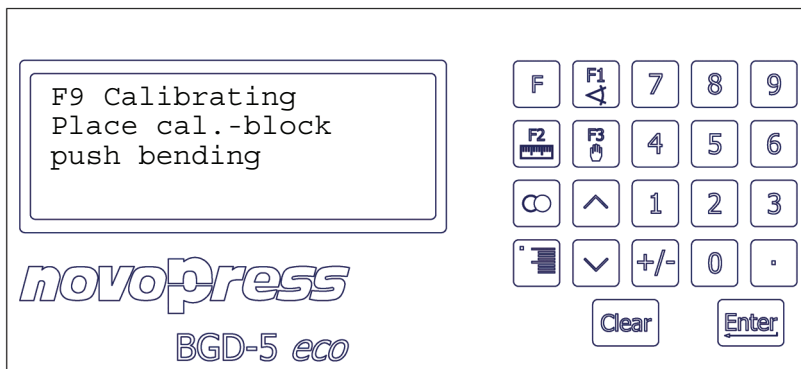

*The zero point has to be reset.*

- Insert control bar (4) with the V groove pointing towards the bending mandrel (12).



### **Note!**

***Always use the control bar supplied to set the zero point.***

***The 10mm bending radius (9) must be attached to the bending mandrel (12).***

- Press the **Bending** button, and hold until the hydraulic unit switches itself off.  
*The tool holder (2) moves to the control bar (4) and then moves back again.  
The following will appear on the display.*

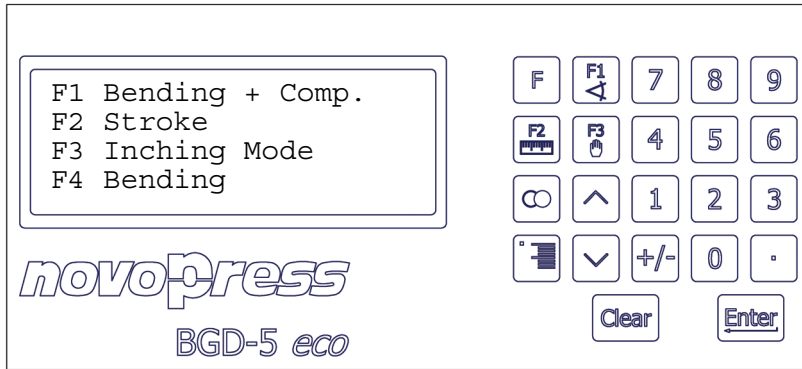

*Zero point setting for the bending operation has been completed.*

- Remove the control bar (4).

**Note!**



The control bar must only be used for setting the zero point.

Only a slight amount of force is needed for calibration when setting the zero point. The bending process produces a maximum force of 150 kN.

***Non-compliance with this instruction will lead to damage to the control bar and the BGD.***

**Note!**



The zero point has to be reset every time there is an interruption to the power supply, including after the emergency off button has been pressed.

To avoid having to do this the bending table can be put in stand-by. The display will then be empty.

## 11 Bending

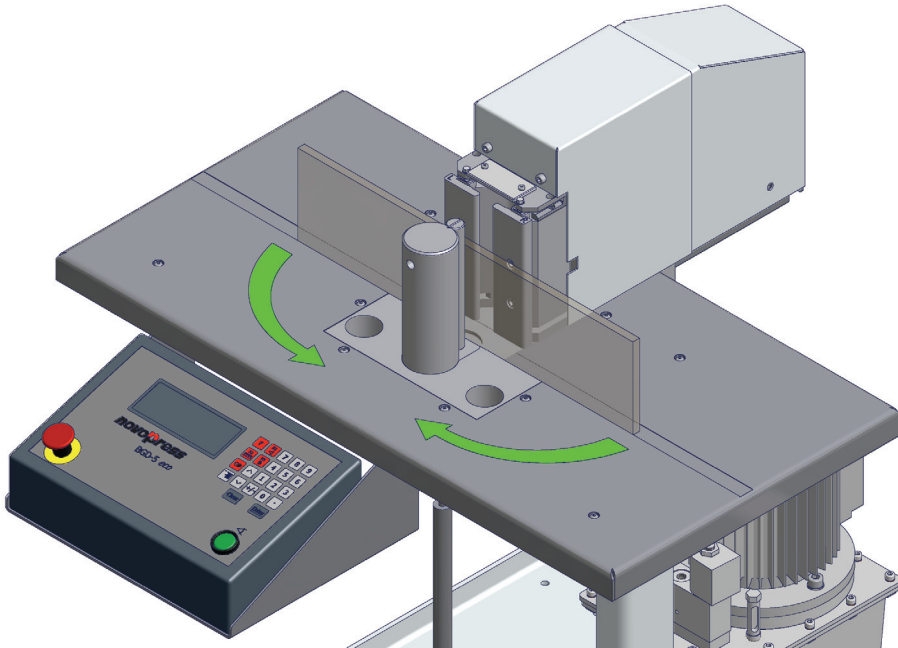



### 11.1 Bending and compensation (function F1)

#### Procedure

- Press the  button.

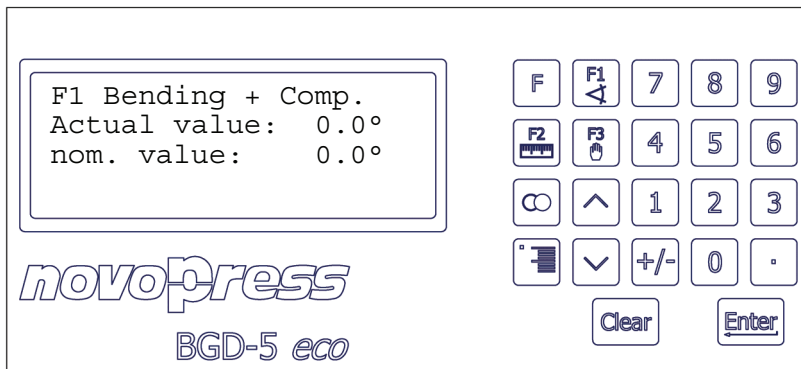
*The following will appear on the display.*



- Enter the bending angle and confirm using .



#### **Note!**

**Values of between 0.5 and 93.0 degrees may be entered.**

- Insert bar.
- Place the length of the shank on the measuring tape.



#### **Note!**

**During the bending process, the bar shanks move in the direction indicated by the arrows.**

**Protect this area when bending long bars.**

- Actuate the **Bending** button and hold it down until the bending tool has retracted fully.

### Bending operation sequence

- Press the **Bending** button and hold.
- The bar is pre-bent.
- The computer interrupts the bending process for a short while and measures bar springback.
- The bar is repeatedly bent until the angle value entered is attained.
- Once the bending process is complete, release the **Bending** button.

### Re-bending bars already bent (compensation)

If a bar that has already been bent has to be bent again, enter the required angle and bend

using .

- Example:*
- Re-bend 11 degrees
  - Bar is already bent to 30 degrees
  - Enter 41 degrees

## 11.2 Stroke limit (function F6)

The stroke limit is only active with the function F1 "Bending and Comp."

When the stroke limit is set, the tool holder retracts up to the entered value in front of the cylinder. For a bar with a thickness of 10 mm, the return stroke can be limited to approx. 20 mm. If the bar is thinner, the return stroke can be set larger, e.g.: 5 mm bar with 25 mm return stroke.

The return stroke must be entered first, then bending can commence.

The stroke limit value is stored for the duration that the bending table is connected to the electricity supply. To switch off the stroke limit, set the value of the return stroke to zero.



The tool holder returns to its starting position as soon as you exit function F1.

### Procedure:

- Press the  key and then .

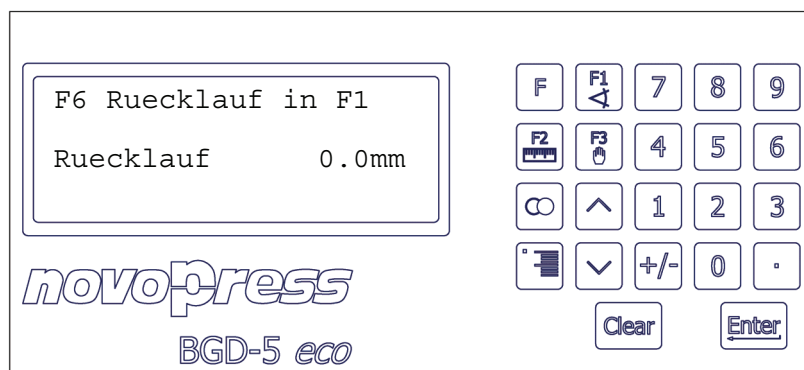
*The following will appear on the display:*



- Enter the return stroke, e.g.: 20 mm, and confirm with .
- Press the  key.

*The following will appear on the display:*

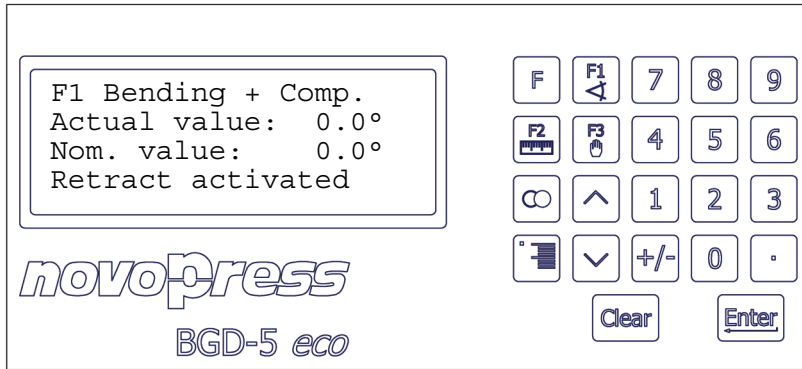

- Now enter the bending angle and confirm with **Enter**.
- Perform bending operation.  
*When bending is complete, the tool holder moves up to 20 mm towards the cylinder.*

### Clearing the entered stroke limit

To clear the stroke limit, set the value that you entered via function F6 to zero.

- Press the **F** key and then **6**.  
*The following will appear on the display:*

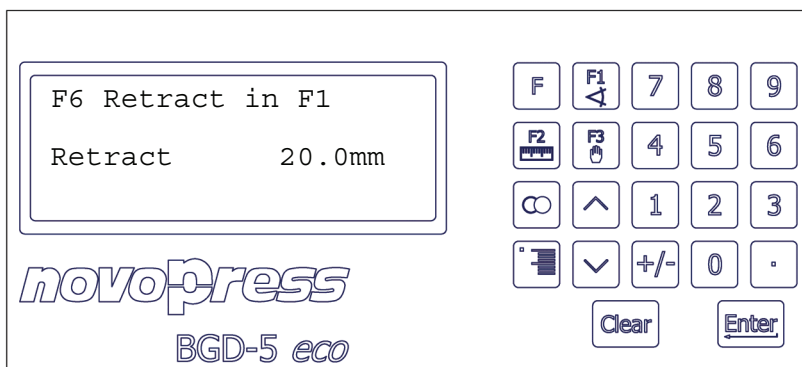

- Enter a return stroke of 0 mm and confirm with **Enter**.  
*The stroke limit is now deactivated.*

### 11.3 Bending using the Repeat key

Bending using the Repeat key is only possible for function F1 "Bending + Comp."

Bend a bar using the F1 function.

The corrected bend angle of the bar bent last will be stored.

After this, bars made of the same material and with the same cross section can be bent without measuring the springback.

In order to do this, first press the Repeat key  and then actuate the **Bending** button.

#### Procedure

11.3.1 Bend the bar using .

11.3.2 Take out the bar. Insert a new bar.

11.3.3 Press the Repeat key .

*The following will appear on the display.*

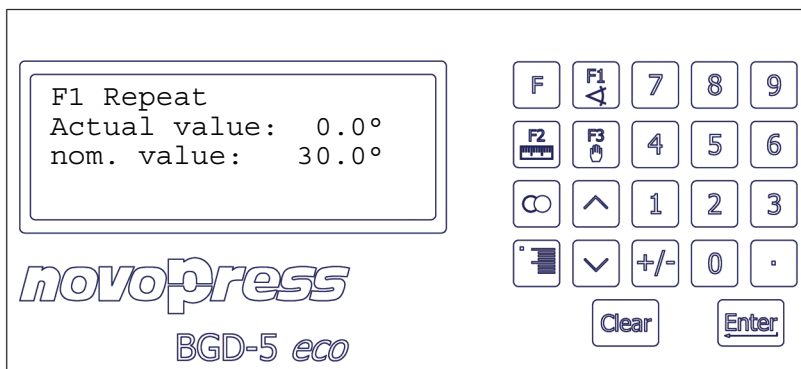

11.3.4 Press the **Bending** button and hold.

*The bar will be bent.*

11.3.5 Release the **Bending** button as soon as the bending process is complete.

11.3.6 Take out the bar. Insert a new bar.

11.3.7 Repeat points 11.3.4 to 11.3.5 as often as required.

11.3.8 To exit the repeat function press .

#### 11.4 Bending bars less than 5 mm thick (F4 bending without compensation)

For these bars the springback cannot be measured accurately.

The bars are bent without measuring the springback. Then measure the bent angle and enter a larger angle if necessary before bending again. Repeat this procedure until the required angle has been attained.

- Press the **F** button and then **4**.

*The following will appear on the display.*



- Enter the bending angle and confirm using **Enter**.
- Insert bar.
- Place the length of the shank on the measuring tape.
- Press the **Bending** button and hold until the bending process is completed.
- Take out the bar.  
Check the bending angle.
- If the required angle was not achieved, set a larger angle.
- Repeat the procedure for as long as necessary until the required bending angle is attained.

## 12 Step bending tools

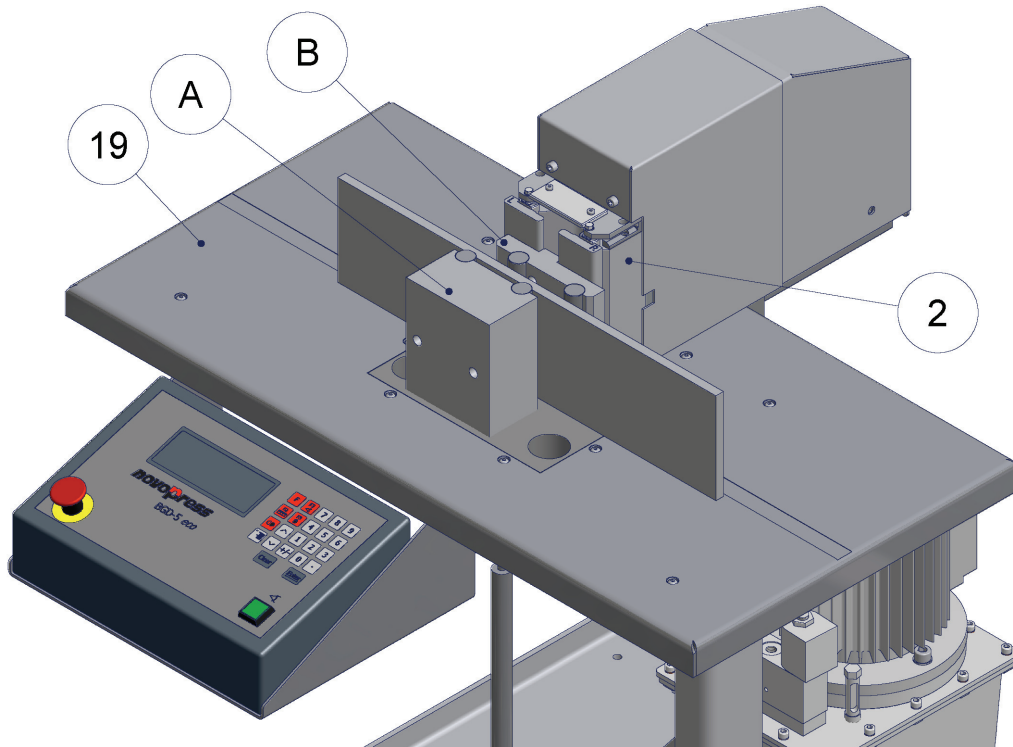

### 12.1 Range of application

Copper and aluminium bars can be bent using the step bending tools.

The maximum cross-section is as follows:

**for step bending tool (small), order no.: 31671**

for aluminium:	120 x 10
for copper:	80 x 8
	60 x 10

**for step bending tool (large), order no.: 31188**

for aluminium:	120 x 10
for copper:	120 x 10

The maximum step height for the relevant cross-sections can be taken from the table.

Smaller step heights can also be achieved by limiting the stroke accordingly.

The stroke settings for

$$\text{step height} = \text{material thickness}$$

are also listed in the table.



The values shown in the table are only intended as guidelines. The precise settings depend on the individual material and must be determined by means of test bends.

### 12.2 Installing the step bending tool

- Pull the bending mandrel out of the workplate (19).
- Install part 2 of the step bending tool (B) in the tool holder (2) (screw M 6 x 70).
- Insert part 1 of the step bending tool (A) in the bending mandrel holder.



## Procedure

Step bending can be carried out using the functions  Stroke or  Inching mode.



### Note!

Bending tool part 1 shall be adjusted parallel to the table measuring tape with the aid of the bar to be bent, before each bending operation.

**Disregarding this instruction will falsify the bending operation.**

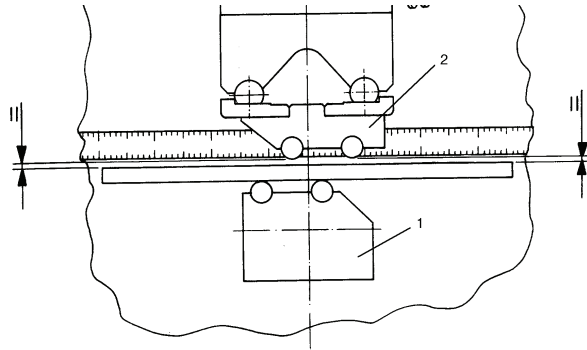



## 12.3 Inching mode

- Press .

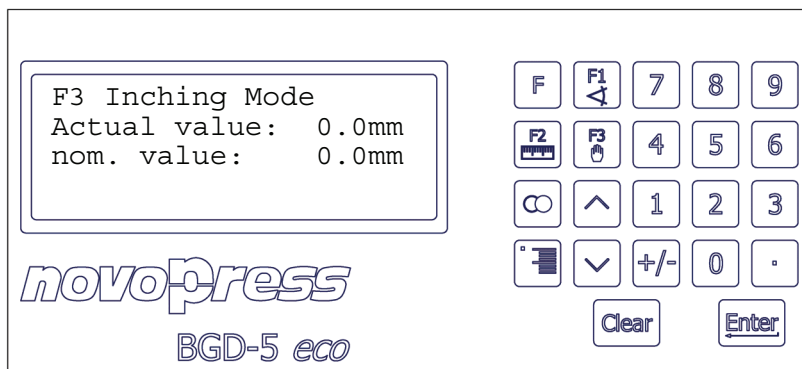
*The following will appear on the display.*



- Enter the stroke and confirm using .
  - Insert bar.
  - Adjust the length of the shank on the measuring tape.
  - Press and hold the **Bending** button until the required step is bent.
    - The tool holder (2) is transported forwards for as long as the **Bending** button is pressed. As soon as the **Bending** button is released, the tool holder stops.*
    - or:*
    - The tool holder moves forwards until the stroke entered has been attained and then comes to a halt.*
  - Release the **Bending** button.
    - The tool holder (2) stops.*
  - Press  or .
- The tool holder (2) returns.*

or:

## 12.4 Stroke

- Press .

*The following will appear on the display.*

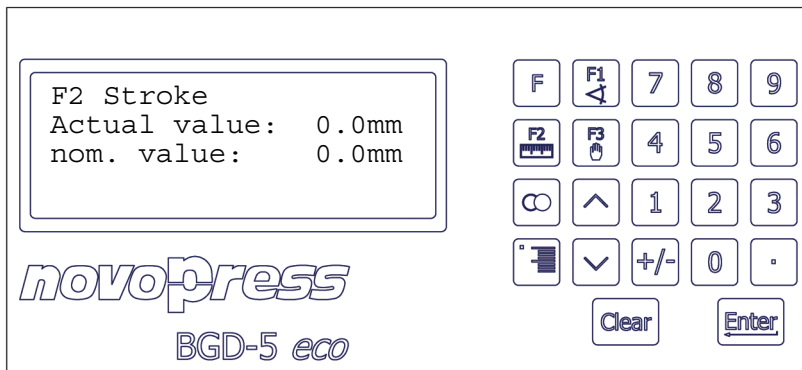

- Enter the stroke and confirm using .
- Insert bar.
- Adjust the length of the shank on the measuring tape.
- Press and hold the **Bending** button until the required step is bent.
 

*The tool holder (2) is transported forwards for as long as the **Bending** button is pressed. As soon as the **Bending** button is released, the tool holder is transported backwards.*

*or:*

*The tool holder moves forwards until the stroke entered has been attained and then moves back.*
- Release the **Bending** button.
 

*The tool holder (2) returns now if it has not done so before.*

### Tables for step bending tools

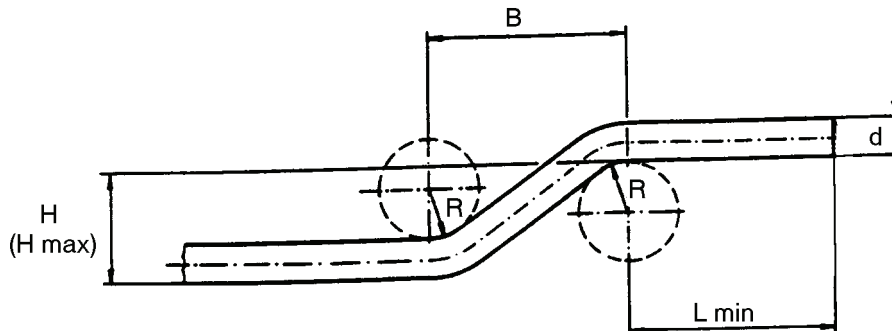

#### 12.5 Step bending tool (small), order no.: 31671

Min. length for insertion L min = 23 mm  
 Bending radius R = 7.5 mm  
 Width of step B = 21 mm

Material	Width x thickness	Max. step height Hmax (mm)	Step height H (mm)	Stroke (mm) to be set in order to bend step height H
Aluminium	50 x 4	16	4	9
	40 x 8	18	8	6.8
	80 x 8	18	8	6.8
	60 x 10	21	10	5.8
	120 x 10	9	-	-
Copper	60 x 5	17.5	5	7.8
	40 x 8	20	8	6.8
	80 x 8	18	8	6.8
	40 x 10	19	10	6
	60 x 10	10	10	6

The values shown in the table are only intended as guidelines. The precise settings depend on the individual material and must be determined by means of test bends.

**12.6 Step bending tool (large), order no.: 31188**

Min. length for insertion L min = 39 mm  
 Bending radius R = 10 mm  
 Width of step B = 37 mm

<b>Material</b>	<b>Width x thickness</b>	<b>Max. step height Hmax (mm)</b>	<b>Step height H (mm)</b>	<b>Stroke (mm) to be set in order to bend step height H</b>
Aluminium	50 x 4	22	4	9
	40 x 8	25	8	6.2
	80 x 8	25	8	6.2
	120 x 10	28	10	4.2
Copper	40 x 6	23.5	6	6.8
	80 x 6	23.5	6	6.8
	60 x 8	25	8	6
	80 x 8	25	8	6
	40 x 10	26	10	4.8
	120 x 10	25.5	10	4.8

The values shown in the table are only intended as guidelines. The precise settings depend on the individual material and must be determined by means of test bends.

### 13 Upright bending tool, order no. 31221

#### 13.1 Range of application

Copper and aluminium bars with a max. cross section of 50 x 10 mm can be bent using the upright bending tool.

The max. bending angle depends on the bar width.

Width	Thickness	Max. bend. angle
Up to 40 mm	Up to 10 mm	90°
50 mm	Up to 10 mm	45°

The bar thickness determines which thrust pads (18) are to be used.

There is a set of thrust pads available for bars with widths of 20 and 30 mm and one for those with widths of 40 and 50 mm.

The bar thickness is indicated on the thrust pads (18).

#### 13.2 Installing the upright bending tool

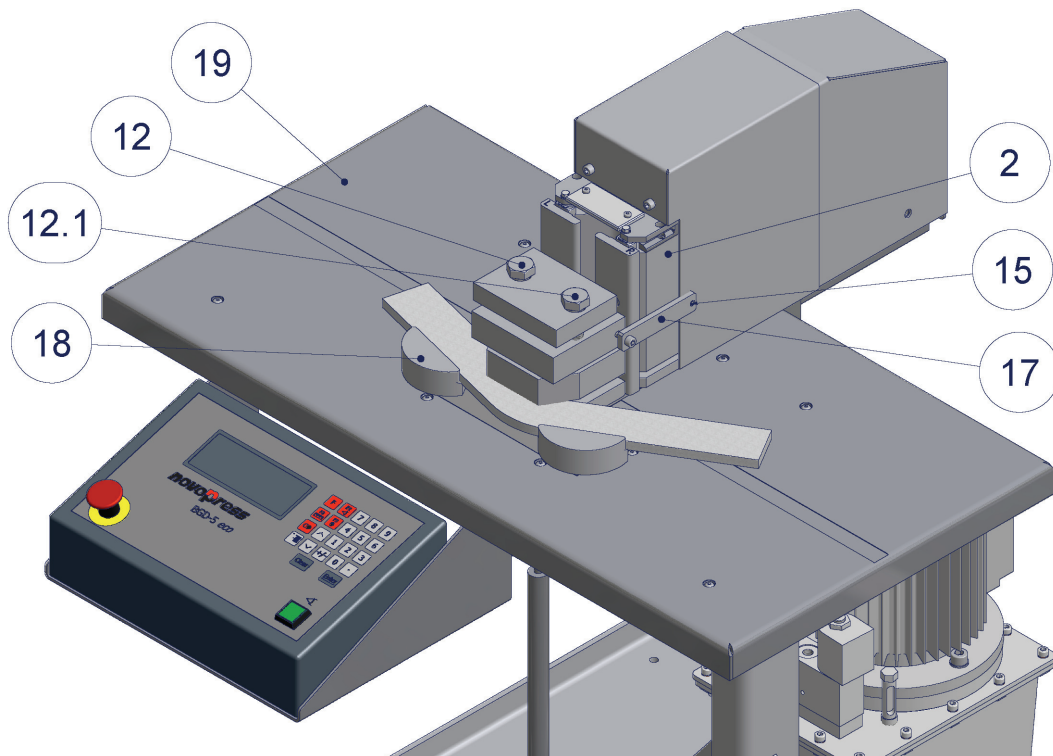

- Pull the bending mandrel and both plastic plugs out of the workplate (19).
- Put the upright bending tool on the workplate (19).
- Pull the securing plates (17) apart and move the upright bending tool towards the tool holder (2).
- Release the plates (17).  
*The holding pins (15) on the securing plates (17) should engage behind the tool holder (2).*
- Insert the thrust pads (18) required, e.g. for the bars with a width of 40/50 mm, with the face side towards the bar.  
Use the thrust pads for bars with a thickness of 20/30 mm to bend Z angles if the stroke does not suffice.



### 13.3 Procedure

Only the Inching mode function  may be used for upright bending

- Push the bar into the upright bending tool.
- Determine the shank length.
- Fix the bar in the bending tool by tightening the clamping screws (12) and (12.1) slightly.
- Press .

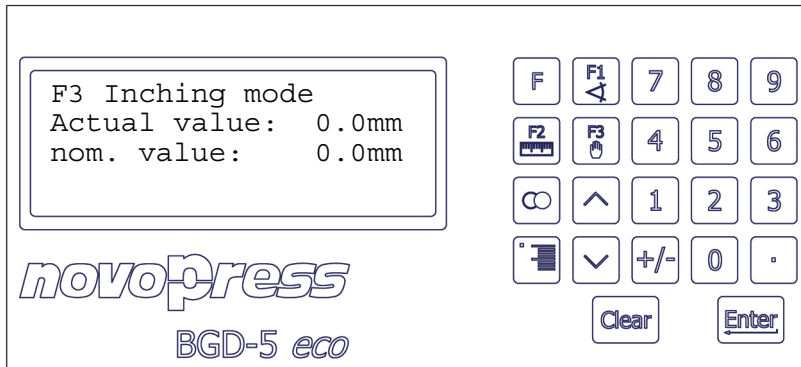
*The following will appear on the display.*



- Enter the stroke and confirm using .
  - Press the **Bending** button until the hydraulic unit switches itself off.  
*After the bending operation, the upright bending tool stops.*
  - Loosen the clamping screws.  
**WARNING! Loosen screw 12.1 first, then screw 12.**
  - Press  or .
- The tool holder (2) returns to its starting position.*
- Remove the bar from the bending tool.  
Check the bending angle.
  - Increase the stroke if necessary.
  - Repeat until the required bending angle is achieved.



#### Note!

**On dismantling the upright bending tool, insert the two plastic stops into the workplate.**

## 14 Additional bending tool for small lug lengths, order no.: 31850

### 14.1 Range of application

Using the additional bending tool, order no.: 31850, small lug lengths up to 25 mm can be bent.

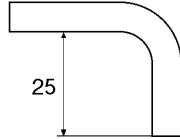

The maximum cross-section is as follows:

for aluminium:	120 x 10
for copper	120 x 6
	80 x 8
	60 x 10

### 14.2 Installing the additional bending tool

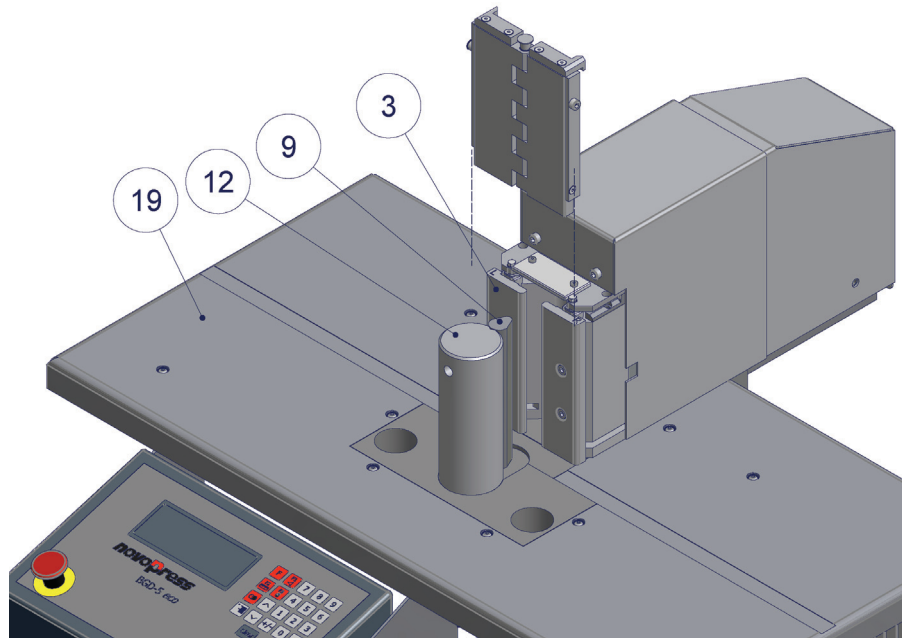

- Pull the bending mandrel (12) out of the workplate (19).
- Unscrew bending radius (round) (9).
- Screw on drop-shaped bending radius.
- Insert the bending mandrel (12) into the workplate (19).
- Insert the additional bending tool in front of the thrust pads (3). Ensure that the additional bending tool grips behind the top of the thrust pads.



#### **Note!**

***Use drop-shaped bending radius only in conjunction with additional bending tool.***

### 14.3 Bending

See "Bending" section

## 15 Hydraulic unit HA3 BGD 400V

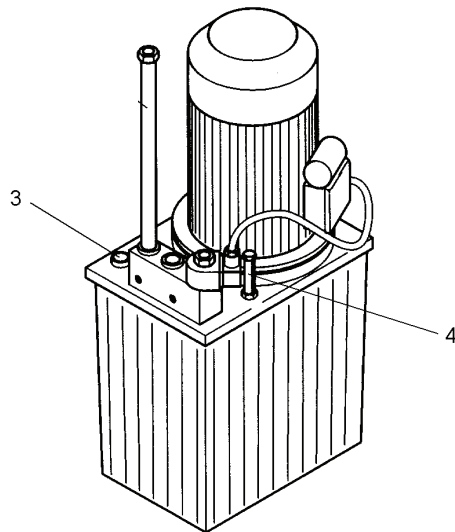

### Construction

An oil-filling screw with bleeder valve (3) and an oil gauge (4) are mounted on the oil tank cover.

#### **Oil gauge (4)**

The oil gauge dipstick must be between the two markings. If the dipstick is at the lowest marking, oil needs to be added.

#### **Bleeder valve (3)**

The bleeder valve closes if the tank is on a slant (no oil can emerge).

In vertical position (operating position), a slight oil vapour may be carried with the escaping air. The oil film which is thus created on hydraulic equipment should be removed from time to time.



### **Warning!**

The unit ***must not*** be switched on when lying horizontally. There is a risk that the pump will not draw in oil and is damaged as a result.

### Operation

- Pushing the **Bending** button on the BGD bending table puts the unit into operation.



### **Note!**





- Care should be taken to ensure that the oil temperature does not exceed 70 °C during operation.
- Pressure can only be built up again once the button has been released and actuated again.



## 16 Table of functions/ brief instructions

A function is selected by pressing the  key and entering a number.



The following keys are available for functions F1, F2 and F3: , , 

Fct	Meaning
F0	Stand-by
F1 or 	<p>Bending + Comp.</p> <p>Enter angle. Actuate <b>Bending</b> button. The bar springback is measured. The bar is bent until the angle entered is attained.</p>
F2 or 	<p>Stroke</p> <p>For step bending Enter the stroke. The tool holder moves forwards as long as the <b>Bending</b> button is actuated or until the stroke set is attained. After the <b>Bending</b> button has been released or the stroke set has been attained, the tool holder retracts.</p>
F3 or 	<p>Inching mode</p> <p>For step and upright bending Enter the stroke. The tool holder moves forwards as long as the <b>Bending</b> button is actuated or until the stroke set is attained. After the <b>Bending</b> button has been released or the stroke set has been attained, the tool holder comes to a halt. Press  or  in order for the tool holder to return to its starting position.</p>
F4	<p>Bending</p> <p>Enter the angle. Actuate the <b>Bending</b> button. The bar is bent to the angle entered without measuring and adjusting the springback (for bars with a thickness of less than 5 mm).</p>
F5	<p>Current angle</p> <p>Is displayed if a bar is pressed against the thrust pieces.</p>
F6	<p>Retract in F1;</p> <p>Enter the stroke value for the return stroke limit. After the next bending operation the bending tool comes to a halt at the stroke value entered.</p>
F9	<p>Calibrating</p> <p>Insert the control bar. Actuate the <b>Bending</b> button. The bending tool's zero position is reset.</p>

## 17 Setting options for the user in the menu



You can use the menu to change some of the BGD settings, such as language, unit of measurement for length etc.

You only have access to “User Level” and “Setter Level”. The other menu items are blocked and cannot be accessed by the user.

Use the  and  keys to move from one parameter to the next.

Press  to save newly entered values.

You should note down any values that you change so that you can reset the bending table to the default values if necessary.

If you do not want to save the newly entered value, do not press . Press the  or  keys instead. The original value is kept.

### 17.1 User Level

#### Parameters and input options for “User Level”

Parameter	Function						
P 0	Factor for the bending operation (to adjust the factor see page 33)						
P 1	Factor for the stroke (default value 1800)						
P 2	Switching from inch to mm <table border="1" data-bbox="742 1167 1086 1319"> <thead> <tr> <th>Setting</th> <th>Display in</th> </tr> </thead> <tbody> <tr> <td>0</td> <td>mm</td> </tr> <tr> <td>1</td> <td>inch</td> </tr> </tbody> </table>	Setting	Display in	0	mm	1	inch
Setting	Display in						
0	mm						
1	inch						
P 5	Language <table border="1" data-bbox="730 1373 1098 1525"> <thead> <tr> <th>Setting</th> <th>Language</th> </tr> </thead> <tbody> <tr> <td>0</td> <td>English</td> </tr> <tr> <td>1</td> <td>German</td> </tr> </tbody> </table>	Setting	Language	0	English	1	German
Setting	Language						
0	English						
1	German						
P 6	Unit code, indicates the hardware version (cannot be changed)						
P 7	Current software version of the unit (cannot be changed)						
P99	Total number of strokes/ bends performed (cannot be changed)						

Proceed as follows to access “User Level”.

- Press .

The following will appear on the display.



- Confirm using .

1502, for example, appears on the display.



The individual “User Level” parameters can be viewed using the following keys



### Changing a parameter

- Enter the new value.
  - Confirm using .
- The previous value will be overwritten and the next parameter is displayed.

- To exit "User Level"

press 

*The following will appear on the display.*



- Press  again.

*The following will briefly appear on the display.*



*The values have now been saved.*

*You are now in normal operating mode again.*

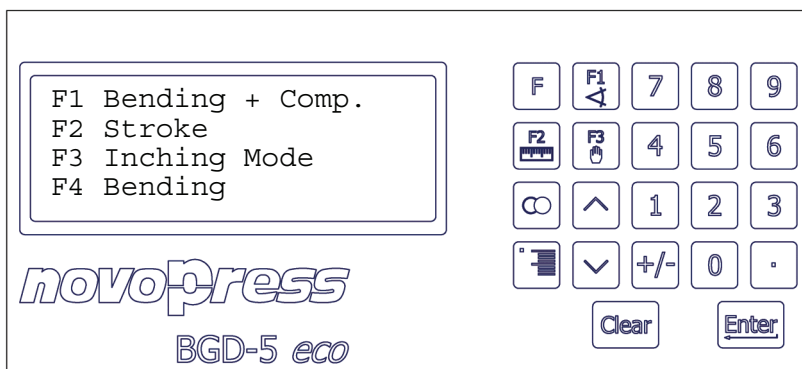

## 17.2 Setter Level

## Parameters and input options for "Setter Level"

Parameter	Function		
P3	Zero point adjustment for stroke. 0.0 mm is standard. After changing the zero point, the bending table has to be switched on and off again so that the change is activated.		
P6	Display in F1 bending mode		
	Setting	Display	Example
	0	Nominal value only	<div style="border: 1px solid black; padding: 5px; width: fit-content;">           F1 Bending + Comp.            nom. value:            30.0°         </div>
	1	Nominal value and actual value	<div style="border: 1px solid black; padding: 5px; width: fit-content;">           F1 Bending + Comp.            Actual value: 1.9°            nom. value: 30.0°         </div>
	2	For bending, the springback value after the first bending attempt is displayed. This function is for service purposes	<div style="border: 1px solid black; padding: 5px; width: fit-content;">           F1 Bending + Comp.            Bend1 23.2°            nom. value: 30.0°         </div>
3	The angle actually bent is displayed	<div style="border: 1px solid black; padding: 5px; width: fit-content;">           F1 Bending + Comp.            Angle: 30.1°            nom. value: 30.0°         </div>	

**Proceed as follows to access the “Setter Level” menu**

- Press .

*The following will appear on the display.*



- Press .

*The following will appear on the display.*



- The code is 4040.
- Confirm using .



*The following will appear on the display.*

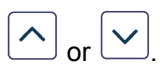

The individual “Setter Level” parameters can be viewed using the following keys



## Changing a parameter

- Enter the new value.
- Confirm using .  
The previous value will be overwritten and the next parameter is displayed.
- To exit "Setter Level"  
press .

*The following will appear on the display.*



- Press  again.

*The following will appear on the display.*



*The values have now been saved.*

*You are now in normal operating mode again.*

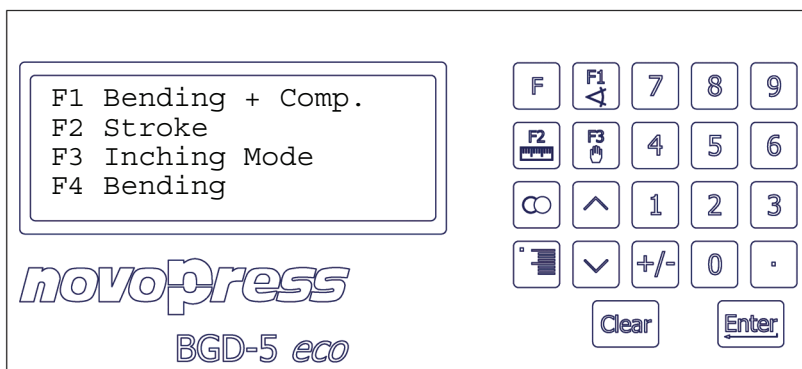

## 18 Adjusting the bending factor

If the angle bent is always one constant unit smaller or bigger than the input value,  
e.g. bent angle: always  $59.5^\circ$

input angle  $60^\circ$

then the conversion factor (angular moment/degree) needs to be corrected.

This value has been set at the factory and should only be changed if there actually is a deviation.

### Adjusting the bending factor

- Press .

*The following will appear on the display.*



- Confirm using .

*The following will appear on the display.*



*The factor is displayed: 1502*



- Correct the factor as follows:

<b>Difference = input angle minus bent angle</b>		
input angle	<b>60 deg.</b>	<b>59.5 deg.</b>
bent angle	<u><b>-59.5 deg.</b></u>	<u><b>-60 deg.</b></u>
	<b>+ 0.5 degrees</b>	<b>- 0.5 degrees</b>

**1 pulse equals 0.06°.**       $\frac{\text{Difference}}{0.06 \text{ deg.}} = \text{Pulses}$

Example: +0.5 degrees:  $0.06^\circ = \text{app. } +8 \text{ pulses}$     Example: -0.5 degrees:  $0.06^\circ = \text{app. } - 8 \text{ pulses}$

If the bent angle is smaller than the input angle, the calculated pulses are added to the input factor.

If the bent angle is larger than the input angle, the calculated pulses are deducted from the input factor.

This means: input factor plus 8 pulses.

input factor minus 8 pulses.

Example: - input factor is		1502		1502
	plus	8	minus	8
- New input factor:		1510		1494

- Enter the new factor. The complete number must be entered.



**Note!**

- Only values from 1470 to 1530 inclusive can be entered.

- Confirm using . The next parameter is displayed.

- To save the value you have entered

press .

*The following will appear on the display.*



- Press  again.

*The following will briefly appear on the display.*



*The values have now been saved.*

*You are now in normal operating mode again.*

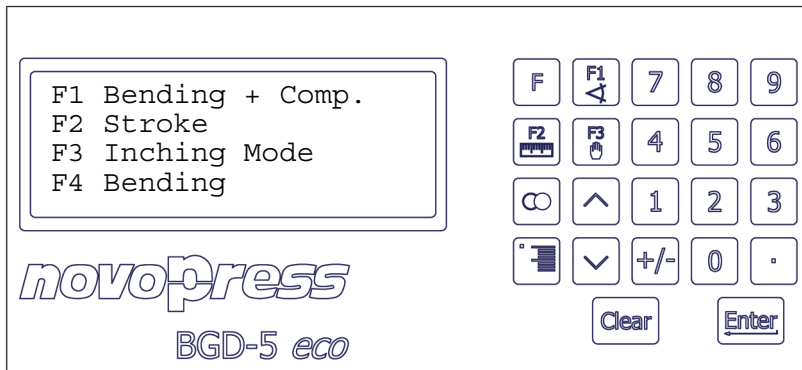

## 19 Error messages

BGD display	Description	Remedy
<pre>F1 Bending + Comp. Actual value:  1.9° nom. value:   30.0° Bending aborted</pre>	<p>The bending operation was not completed.</p> <p>The <b>Bending</b> button was released too early.</p>	<p>Actuate the <b>Bending</b> button again and hold it down until bending has been completed.</p>
<pre>F2 Stroke Actual value:  0.0mm nom. value:   150.0mm Max:          100.0mm</pre>	<p>The stroke entered is too large.</p> <p>A max. of 100 mm is possible</p>	<p>Enter a smaller stroke</p>
<pre>F1 Bending + Comp. Actual value:  0.0° nom. value:   94.0° Min:          0.5°</pre>	<p>The angle entered is too small.</p> <p>A min. of 0.5° is possible</p>	<p>Enter a larger angle.</p>
<pre>F1 Bending + Comp. Actual value:  0.0° nom. value:   94.0° Max:          93.0°</pre>	<p>The angle entered is too large.</p> <p>A max. of 93° is possible</p>	<p>Enter a smaller angle.</p>
<pre>F9 Calibrating Actual value:  0.0°  Reference aborted</pre>	<p>The zero point has not been set.</p> <p>The <b>Bending</b> button was released too early.</p>	<p>Actuate the <b>Bending</b> button and hold it down until the bending tool retracts</p>
<pre>Setter Level           4711  Enter Code</pre>	<p>The code has been entered and the display does not change for the next stage. The code was wrong.</p>	<p>Enter the correct code.</p>

## 20 Required space, installation and assembly

### 20.1 Required space

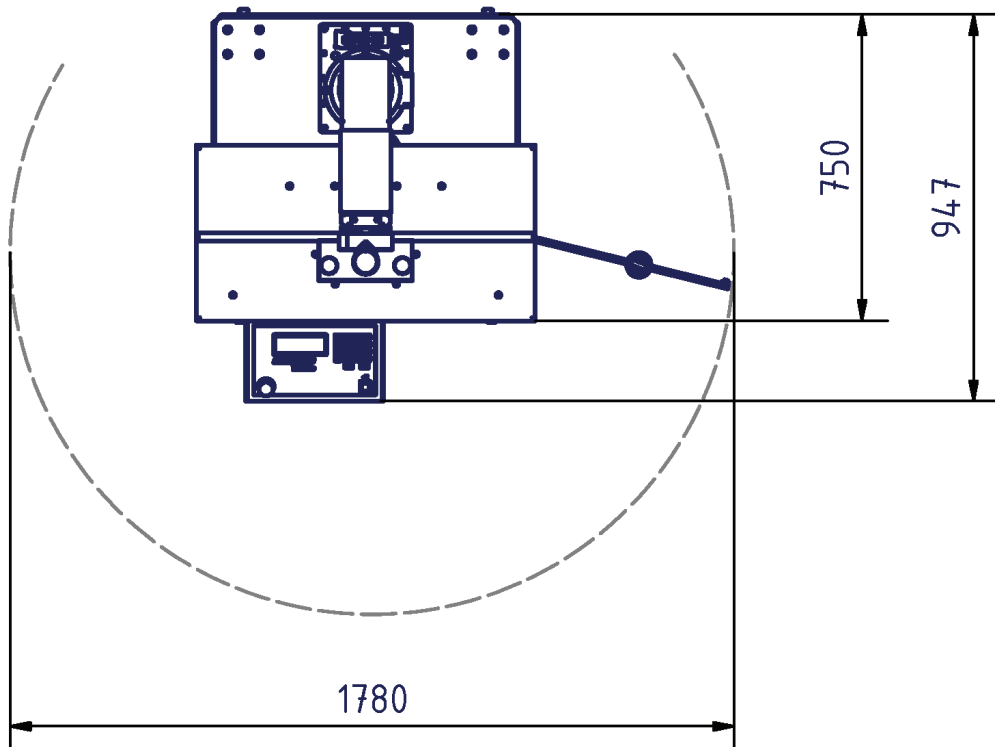
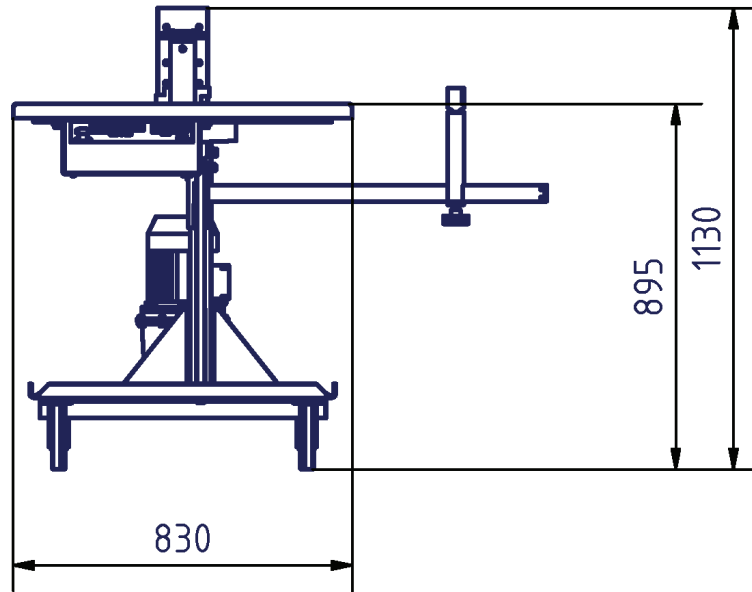

## 20.2 Installation

- The BGD5-eco must:
  - Stand on a level surface
  - Be completely stable
  - Have a sufficiently large working area.
- The BGD5-eco may only be operated with the brake of the relevant rollers engaged.
- The plug or socket must be within easy reach

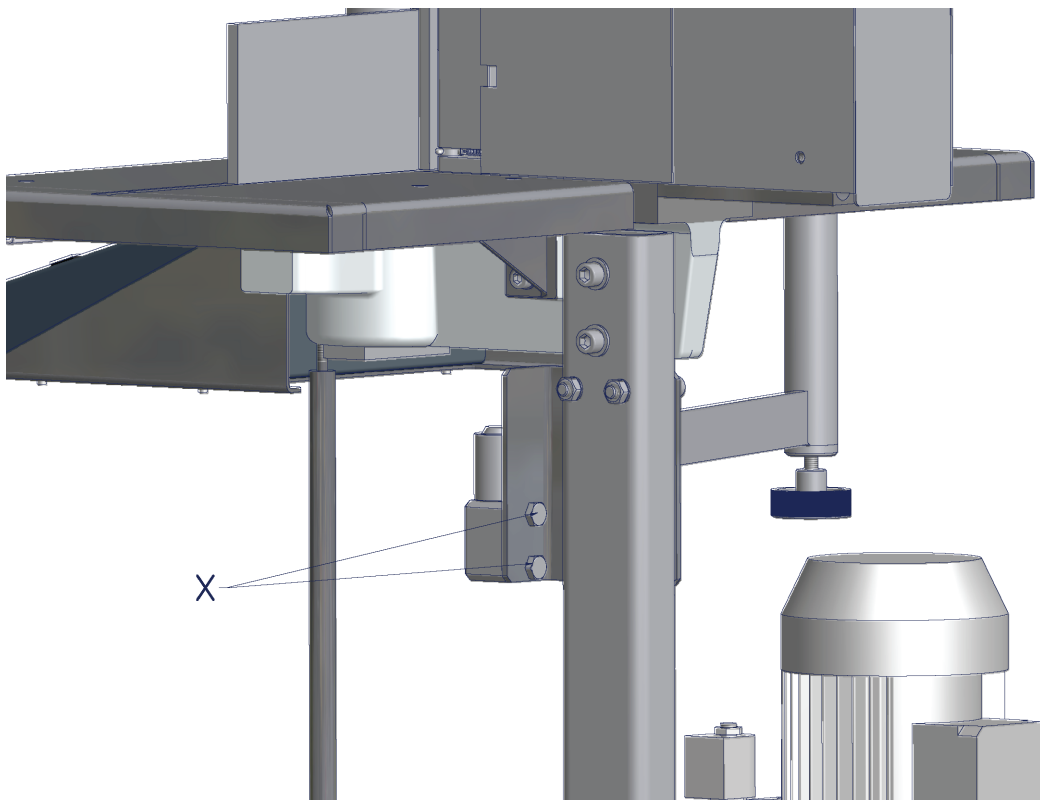

## 20.3 Installing the support arm



Fix the support arm to the bracket using 2 bolts (X).

## 20.4 Commissioning

The system must be vented following transport and after longer periods of standstill. To do so, proceed as follows:

- Follow the instructions in section **10** Start-up.
- Pull out the bending mandrel.
- Press .
- Enter 90 mm and confirm with .
- Press the **Bending** button, and hold until the hydraulic unit switches itself off. Repeat this process approx. 10 times.
- Insert the bending mandrel in the workplate.

## 21 Maintenance of the bending table



### Warning!

**BEFORE ANY MAINTENANCE OR REPAIR WORK, ALWAYS PULL OUT THE MAINS PLUG!**

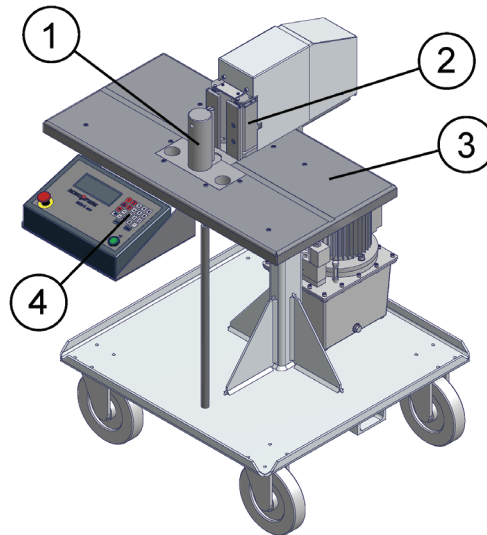

When dirty:  
Every week:

Clean area between bending mandrel (1) and tool holder (2).  
Clean complete bending bench.  
Grease the workplate (3).  
Clean the keyboard (4) with a mild cleaning agent, e.g. a solution of water and kitchen detergent, using a slightly moist cloth.

After approx. 1000 bending ops:

Check the bend angle by means of a test bend. If it is different to the angle entered the bending factor must be adjusted. See Adjusting the bending factor, page 33.

### 21.1 Displaying the number of previous bends

- Press .

*The following will appear on the display.*



- Confirm using .

*P0 will appear on the display.*



- Now move on to parameter 99.
- The number of previous bending operations will be displayed.
- Press  twice to access the normal operating mode.

## 22 Maintenance of the hydraulic unit HA3 BGD 400V

We recommend that our authorised NOVOPRESS specialist workshops be used for repair and maintenance work.

Have the unit maintained by a specialist **only**.



### Warning!

**ALWAYS** PULL OUT THE MAINS PLUG BEFORE CARRYING OUT MAINTENANCE AND REPAIR WORK.

### Checking the oil level

The dipstick of the oil gauge (4) must be between the two markings. If the dipstick is at the lowest marking, oil needs to be added.  
Top up the oil if necessary.

### Oil change

First oil change:	after about 1,000 starts or after 3 months
Subsequent oil changes:	after every 15,000 starts but at least once a year.
Oil volume:	5.5 litres
Hydraulic oil:	See Technical data
Oil filter:	The oil filter is the suction strainer with a mesh width of 0.06 mm.

- Unscrew the oil filling screw with the bleeder valve (3) on the oil tank cover.
- Draw off the old oil by means of suction.
- Fill with new oil.

### Note!

The dipstick of the oil gauge (4) must be between the two markings.

**Cleaning:** Remove the oil film from the hydraulic unit every month.

**Hydraulic hose:** The hydraulic hose must be checked for damage every month.  
Replace the hydraulic hose

- if any cracks, pinches or kinks are visible on the outer layer
- if blister formation is visible
- if pressurised fluid is escaping
- if the hose connector is damaged
- if any discolouration of the outer layer is visible, e.g. due to the effect of solvents.

Hydraulic hoses must be replaced after 5 years, even if there is no visible damage.



**Visual and electrical inspection**

Regularly: Check mains cable including plug and extension cord with plug connectors for visible damage and have repaired, if necessary.

Every 6 months: Inspection in accordance with DIN VDE 0701-1 and DIN VDE 0702-1 for electric devices with protection class I, by a qualified electrician, an authorised workshop or by Novopress Neuss.

**Hydraulic drive unit**

Key:

2 = Hydraulic hose

3 = Bleeder valve

4 = Oil gauge

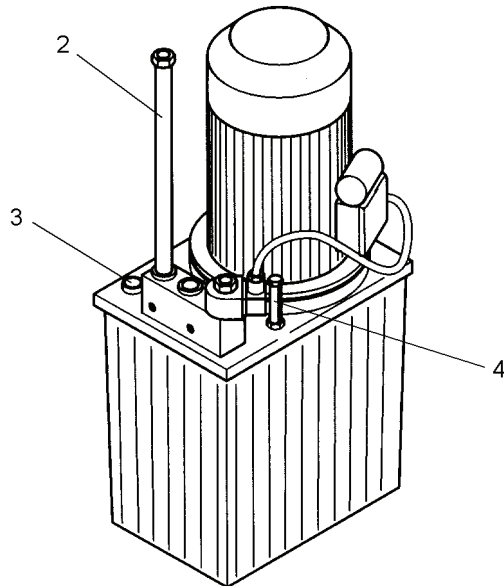

## 23 Fuses and pin assignment

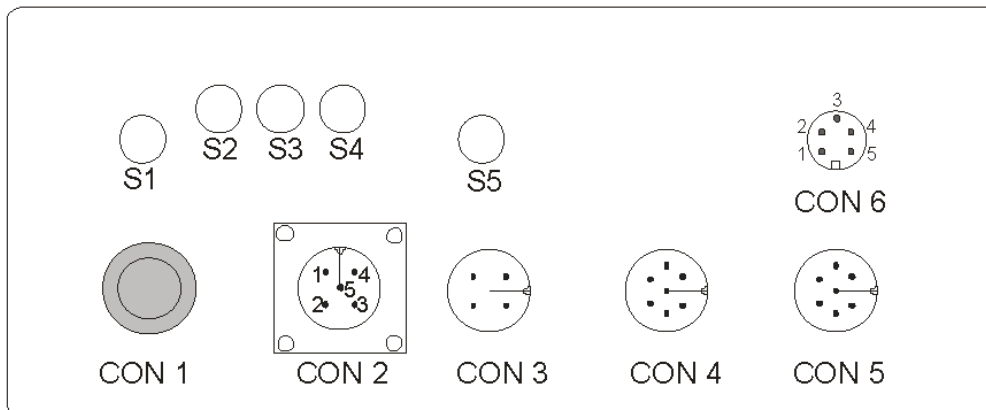

### Fuses

S1	500 mA slow blow up to unit no. 265 1,25 A slow blow from unit no. 266	Electronics
S2	8 A slow blow	Motor
S3	8 A slow blow	Motor
S4	8 A slow blow	Motor
S5	3.15 A slow blow	Valve

### Pin assignment

CON 1	Voltage supply
CON 2	Hydraulic pump switching output
CON 3	Valve output
CON 4	Bending measuring system
CON 5	Stroke measuring system
CON 6	Springback sensor

Repairs / Service

**novopress**



**Uwe Hartig**  
Systemtechnik GmbH

Wettiner Str.24 06193 Wettin-Löbejün  
www.uwe-hartig.de info@uwe-hartig.de  
Germany